

---

**United States Senate  
Committee on Energy and Natural Resources  
May 7, 2013**

**Full Committee Hearing on  
S.783 – “The Helium Stewardship Act of 2013”**

**Testimony of  
Walter L. Nelson  
Air Products and Chemicals, Inc.**

---

**Introduction**

Chairman Wyden, Senator Murkowski and members of the Committee, thank you for the opportunity to testify about helium legislation. My name is Walter Nelson and as Air Products director of helium sourcing and supply chain, I am responsible for identifying where Air Products will get its helium and how it will be delivered to our customers – I feel a personal and professional commitment to be sure that Congress gets helium legislation right.

First, I want to commend the leadership of this Committee for introducing a bill that, while not perfect, reflects real wisdom about how to address the BLM helium situation going forward. This bill accomplishes the goals of maximizing the return to the US taxpayer, ensuring the reliability of supply for end users, honoring contract and property rights, and it does this without disrupting the helium supply chains, all at the same time - very impressive!

I will use my testimony to review how we have arrived at the inflection point on helium that we face today, what choices Congress faces, and what the implications are for the choices that Congress will make. The House recently passed legislation that gives us concern. Helium refiners felt a great sense of relief when your bill was introduced, because it reflects pragmatic ways to approach the controversial issues embedded in the larger helium issue – a phase-in of an auction in a manner that is consistent with reliable helium supply to end users, and respect for existing contracts, which is essential to keeping the entire BLM system functioning properly. While the bill does include a tolling provision that has the feel of an intrusion on private property rights – more or less forcing us, as a condition for doing business with the US Government, to provide use of our employees and use of equipment we invested in for the sole benefit of competitors who chose not to make the same investments that we did. The bill, however, overall strikes a balance that we hope every stakeholder can support.

Let’s be clear: Air Products and the other refiners are committed to assuring that helium in the BLM reserve remains accessible as of the time that BLM pays off its current debt, which by statute would otherwise terminate the federal helium program. The failure to enact legislation in time would be inexcusable, especially since the Senate has had such a broad bi-partisan consensus on a means to that end for over a year. We are glad to see that that same spirit of bi-partisanship continues in the form of

S. 783. We hope that this legislation can move through the Senate promptly and that it will serve as the template for the final law.

### **Air Products and its background in the helium market**

Air Products, with revenues of roughly \$10 billion per year, is an American corporation with a global industrial gas business. The company provides hydrogen for oil refineries so they can produce cleaner-burning gasoline, hydrogen for fuel cell cars and buses, liquid hydrogen for space launches, oxygen for patients in hospitals and to steel mills for use in blast furnaces, nitrogen to enable the manufacture of computer chips, and helium for MRI scanners and semiconductor manufacturing. In short, its core business is helping major industries operate more cleanly and efficiently. Air Products has more than 20,000 employees in over 50 countries.

Air Products is one of the leading suppliers of helium worldwide, and the largest refiner of helium on the BLM pipeline system. To be clear, helium is a byproduct of natural gas. We don't own the gas fields or operate the natural gas plants. Energy companies in that business extract the helium, and it's through our refineries that we supply helium to a wide range of manufacturers. The Company's equipment processes more than half of the helium extracted from the earth globally, and it has pioneered many of the processes critical to getting helium from the ground to vital customers, such as extraction, production, distribution, and storage technologies used in the helium industry today.

That expertise was recognized by virtue of the United States government's selection of Air Products to engineer and construct the first helium extraction units when the federal government began its helium conservation program in 1959. More recently, Air Products designed and constructed the helium enrichment plant in 2003 that supplies the BLM's helium pipeline system, which continues to operate to this day.

Air Products decided to build its first helium refining plant over 30 years ago in the northern panhandle of Texas. The plant, designed and built by Air Products with proprietary technology, was first operational in 1982, expanded in 1985 and upgraded in 2010. Air Products subsequently constructed two more helium refining plants adjacent to a third party natural gas processing plant near Liberal, Kansas. The first plant started production in 1991 and the second plant, when completed in 1999, was the largest helium refining plant in the world. In 1995, Air Products became the first company to design and build a helium refining plant that used crude helium that had been extracted during the production of liquefied natural gas (LNG). More recently Air Products, through a joint venture with Matheson, constructed a helium refining plant in Wyoming. This plant was completed in 2011 and it is expected to begin production later this year when our supplier's natural gas plant becomes operational.

### **Where does helium come from?**

Helium is one of the most abundant elements in the universe, however on earth helium is only found in naturally-occurring underground natural gas reservoirs. Additionally there are a limited number of locations around the globe where helium exists in high enough concentrations to make it economically feasible to capture and refine.

There are no naturally-occurring underground reservoirs of pure helium. Helium is a rare gas and it only forms in certain locations deep below the surface of the earth where the radioactive decay of uranium and thorium occurs with the formation of gas. While there is considerable attention to the discovery of

gas formations throughout the US and the world, helium tends not to be found in most of them. The largest gas fields that are known to contain helium today are located in the United States, Algeria, Qatar, Australia, Iran and Russia. Approximately 75 percent of the world's helium supply currently comes from the United States, with 30 percent originating from the US Government's Federal Helium Reserve.

Helium refiners purchase crude helium from energy companies that are extracting helium from methane-rich natural gas, as well as from the BLM. Refiners then purify the helium, liquefy it by cooling it to -450 degrees Fahrenheit, and then transport and sell the helium into the global retail market. Once helium is extracted, purified, and liquefied, it has a shelf life of only 30 to 45 days before it begins to warm up and turn back into a gas. The liquid helium is transported globally from the liquefaction facilities to other facilities where the product is repackaged into cylinders, tube trailers and dewars for ultimate delivery to customers.

### **The history of Congress's role in assuring sensible management of helium supplies**

The recognition of the significance of helium to the national defense and for research and medical purposes prompted Congress to pass the Helium Conservation Act of 1925. From 1929 until 1960, the federal government was the only domestic producer of helium. The majority of the helium originally produced was used to support the Navy's rigid airship program, the precursor to today's blimps. During World War II, some helium was used in the Manhattan Project. Helium, in short, was vital to national defense.

After World War II, Congress advanced the cause of helium conservation through the Helium Act Amendments of 1960, pursuant to which Air Products constructed all nine of the original helium extraction units, a testament to the company's leadership in the field. The federal government then purchased all of the helium that was extracted and stored it in the Bush Dome, a geological structure within the Cliffside natural gas field located north of Amarillo, Texas. In 1973 the government stopped buying helium because it had accumulated more than enough helium for strategic uses as well as accumulated in excess of one billion dollars of debt over the 10 year conservation period.

Between 1980 and 2000, private industry constructed six helium refining plants at different locations along the BLM's 450 mile crude helium pipeline that extends from northern Texas through the panhandle of Oklahoma and into Kansas, to produce high-purity gaseous and liquid helium from both private and federal crude helium supply. In addition, these private companies began entering into storage contracts with the BLM to store helium in the Bush Dome, creating what became known as the BLM pipeline system, a unique and complicated intersection between private industry and government where both government and private helium is co-mingled in storage under private land. The crude helium is produced by a privately owned plant operated by the government, and is then transported hundreds of miles through a government-owned pipeline, where it is finally purified by privately owned refining plants. This system and its operations are very unique and only exist in the United States.

The commitment to privatization ushered in by Congress in 1995-96 prompted a reassessment of the historical federal role in helium, motivated by a desire to get the federal government out of enterprises that could be handled by the private sector. The result was the Helium Privatization Act of 1996. BLM was directed to shut down and close the government-operated helium refining plant near Amarillo, Texas, and to offer for sale the 30+ billion cubic feet of crude helium stored in the Federal Helium Reserve to private industry. Congress also directed that BLM's helium reserves were to be offered for sale over a 15 year period to pay off the \$1.3 billion debt to the United States Treasury that was

accumulated over 10 years during the helium conservation program. Congress contemplated a more extreme and immediate exit from the helium business but realized that such a course of action would have disrupted the market and been imprudent from the standpoint of the taxpayer and the end users of helium. Very similar conditions also exist today.

### **The Federal Helium Reserve is essential to a stable helium market**

The BLM today operates as a natural gas producer at the Cliffside field, where it extracts natural gas from wells, separates the gas, and then sells the natural gas and helium to private industry. BLM produces approximately two billion cubic feet of crude helium annually, which is about 30 percent of the worldwide supply. The BLM system consists of the Bush Dome, an underground storage reservoir where the United States government stockpiled helium during the conservation period and into which companies that have refined helium can deposit the helium until it is used; together with multiple natural gas wells that are used to extract natural gas from the ground and a gathering system of pipes which connects all the wells together; a helium enrichment plant to process the gas; and a 450 mile crude helium pipeline system that extends from northern Texas across the panhandle of Oklahoma and into Kansas.

The crude helium enrichment plant is operated by the BLM, but the plant is owned by an entity called the Cliffside Refiners Limited Partnership (CRLP), a partnership made up of helium refiners that owned facilities on the BLM pipeline in 2000. The CRLP partners include Air Products, Praxair, Linde (formerly the British Oxygen Company), and Colorado Industrial Gas (formerly owned by El Paso Energy and recently acquired by Kinder Morgan). The CRLP was formed in July 2000 with the charter to support the federal government in fulfilling the requirements of the Helium Privatization Act of 1996. The CRLP invested over \$26 million at the Cliffside field to fund design and construction of the crude helium enrichment plant. BLM operates the CRLP-owned plant today, enabling the sale of government helium and natural gas (methane, in this case) to private industry. The CRLP was honored for excellence by the Secretary of the Interior Gail Norton in 2004 – receiving the Four C's Award which exemplified Secretary Norton's Four Cs philosophy of consultation, cooperation and communication all in the service of conservation.

The BLM pipeline infrastructure today supports private industry by connecting eight private crude helium extraction plants and six private liquid helium refining plants to the BLM's reservoir at Cliffside. Without this pipeline system, private industry would not be able to efficiently deliver crude helium from the extraction plants to the helium refining plants in the region. The BLM pipeline system and the private industry helium plants together supply approximately two-thirds of the worldwide helium supply.

### **Helium privatization could not have been possible without private investments**

In 1996 Congress decided it wanted to privatize the helium in the BLM reservoir. I would like to direct your attention to the diagram of the BLM helium system that is attached at the end of this testimony. What sat in the reservoir at that point – in the lower left of the diagram – was a mixture of helium with other gases. Government had injected helium into the reservoir decades before mainly for defense and scientific research purposes. When Congress decided to privatize the helium, the Cliffside helium enrichment unit, which is essential to refining the gas initially, did not exist. Private refiners invested millions of dollars to build it. Without that investment, the helium would still be in the ground. But once we built that plant 2003, the helium started to flow.

The non-refiners (our competitors) did not invest in the helium enrichment plant, nor did they invest in their own helium refineries. They had the resources to do both, but they did neither. They invested elsewhere. These companies, many years later, now complain that we have an oligopoly. Their position is that Congress should legislate that we have to use our private property and our prior investments for their private benefit through tolling. When they urge Congress to force us to use our private resources to refine helium, when they chose years ago not to invest in their own helium refinery, we hope you can understand why it does not feel fair to us. In fact, when we do have excess capacity and the commercial terms are right, we do already enter into “tolling agreements” with companies that do not have their own refining capacity.

### **Helium is essential in many vital walks of life**

Helium is an indispensable element in the production of fiber optic cable, flat panel TVs, semiconductors, dataphones, and MRI scanners. There are no substitutes. Helium has very unique chemical and physical properties that make it essential to modern day life. It is the second lightest element (after hydrogen), and being lighter than air, it is used not just in balloons and airships but in other applications such as military surveillance and communication blimps. Because of its small molecular size, it is ideal for high tech leak detection. Helium is chemically inert and non-reactive which makes it a premier carrier gas for analytical testing and a protective gas for controlled atmospheres used in semiconductor manufacturing.

Liquid helium is the coldest substance on earth, so it is used to keep the electrical coils in MRIs cold, as well as for special low-temperature scientific research. Its low liquefaction point makes it vital to space launches where gaseous helium is used to pressurize and purge the flammable liquid hydrogen fuel. Helium has the highest ionization potential which makes it the gas of choice for high tech metal and plasma arc welding. It has very low solubility and is used to replace nitrogen in diving gas mixtures used by deep sea divers. Helium has very high specific heat and thermal conductivity which makes it ideal for the gaseous cooling of fiber optic cable and nuclear reactors.

### **What is causing the helium shortage, and when will it end?**

The current shortage in the helium market is unprecedented. While the industry experienced a brief helium shortage back in 2006-2007, the current shortage started at the end of 2011 and we expect it to continue through 2013 until new helium sources are brought on-stream. The factors contributing to supply constraints include a decline in helium extraction from natural gas, disruptions in helium production from existing plants, and delays in the start-up of new facilities.

In the United States we have seen a decline in helium production as energy companies focus their drilling plans on natural gas that is rich in liquids rather than the dry gas which typically has more helium. Additionally, the BLM is allocating product because the helium reservoir is now in its final decline phase. In Algeria and Qatar, production of LNG and helium has decreased due to the fragile worldwide economy and maintenance work at the LNG facilities.

We expect helium supplies will continue to remain tight until new helium production begins in Algeria, Qatar and Riley Ridge, Wyoming later this year. The Algeria project is expected to add an additional two percent to worldwide helium capacity, Qatar II up to 18 percent, and the Riley Ridge project up to four percent. Only after these three new plants are operational and existing plants are back running at full

output will the global supply begin to fully stabilize. Looking to the future – new sources of helium will still be required to offset BLM supply declines over the next 10 years and beyond.

This recent history of supply problems proves one thing: if the BLM system is off limits as soon as 2013, current shortages will be considered modest compared to the dire situation that helium users will face.

### **Enactment of a successor to the Helium Privatization Act of 1996 in 2013 is essential**

Air Products and virtually all stakeholders consider it essential for Congress to pass a successor statute that would preserve a system that for the most part has accomplished important objectives: assuring supply to essential uses of helium, preserving a BLM system that has many moving parts that need to work as a whole, and at stable prices. We see no reason to tinker with the essential functioning of the BLM system. But we don't have time to spare, and here's why.

The Helium Privatization Act of 1996 directed BLM to cease pure helium production and to sell off the helium remaining in the reservoir. The Act expires at the end of 2014. The best available modeling predicts that there will still be 10-12 billion cubic feet of recoverable helium remaining in the reservoir at the end of 2014. At current production rates of about two billion cubic feet per year, the reservoir could continue to produce helium for five to six more years.

This same modeling, however, has determined that the reservoir production rates will begin to decline to approximately one billion cubic feet per year after 2016. As a result, the usable life of the reservoir may be extended beyond 2020. This is sufficient time for new planned helium projects to become operational, replacing the lost Federal Reserve helium, but unless there is a successor statute to the expiring Helium Privatization Act of 1996, the BLM system will not be able to continue operations. To repeat: unless BLM has the authority to continue to operate the federal reservoir – which it won't if there is no successor statute – all of the helium that remains in the reserve will be inaccessible. That means that 30 percent of the worldwide supply will be essentially locked up, causing prices to skyrocket, some users with no ability to access helium, and chaos in the economic sectors that now rely on helium.

In fact, though, the time pressure is even worse. Under the statute, once BLM pays off the \$1.3 billion debt accumulated by the federal government during the helium conservation period, pursuant to the Helium Privatization Act of 1996 the self-funded United States Treasury account will be closed and BLM could then only continue operations with appropriated funds. Otherwise, there will be no funding mechanism to allow BLM to operate the federal reservoir or the 450 mile pipeline that acts as a vital supply chain for private industry. When the 1996 Act was written, Congress projected that the reservoir would be depleted by the end of 2014, when the Act expires. Helium has been removed from the reservoir at rates lower than those projected at the time, which is why there remains helium to be managed and a successor statute necessary. Thus, the various walks of life that would come to a halt without helium would be affected not upon the expiration of the Helium Privatization Act of 1996 on December 31, 2014, but when there is no funding mechanism beyond the end of FY2013.

That said, we are confident that with new helium sources becoming operational over the next few years, we will not be back here, petitioning Congress for yet another extension of the helium legislation. As far as we are concerned, once the 1996 Act is extended to account for the sell-off of the remaining helium in the reserve – and we are fairly confident now that we know by when the reserve will be essentially depleted – the federal government will be out of the helium business for good (other than supplying limited helium supplies to federal research and defense needs).

## **Establishing a market price for helium must be done right**

In the context of enacting legislation in a timely manner, Air Products advocates that the Department of the Interior develop and adopt a mechanism to establish a fair and reasonable market price for the remaining crude helium sold by the BLM from the reservoir. We believe the Secretary of Interior should be given authority to conduct a confidential survey and to collect data from private industry, which would be used in conjunction with federal helium royalty data, in order to determine market pricing.

We strongly recommend that Congress make clear that the Department of the Interior follow specific principles when using the confidential survey data to establish the market price. First, the pricing considered must be for volumes of helium that are similar in size to those volumes currently offered for sale by the Secretary. Helium purchases of small volumes will attract spot pricing, which may be higher and therefore will distort the survey data. Second, the pricing considered must be limited to sourcing transactions where the helium is being purchased for the first time. Any prices for the re-sale of wholesale helium in secondary or tertiary transactions must not be considered because these prices will include profit, which will distort the survey data. The confidential survey data collected must be comprehensive enough to characterize all pricing escalation indexes, including any index or reference to the BLM's posted price for conservation helium.

Clear guidance must be provided to the Department of the Interior on which companies should be included in the survey, when the survey must be conducted, what data must be submitted, how the data must be classified, how the data should be interpreted, what the qualifications of the individuals to analyze the data must be, how confidentiality will be maintained, how to address non-compliance, and how to audit or validate the data to ensure falsification does not occur. Including all these requirements in any legislation is impractical. Instead, we recommend that these details be incorporated into the Committee report and in all other reports accompanying this legislation. We look forward to working with the Committee to achieve this important objective.

## **A phased-in auction is the best approach**

The core idea of this bill – an auction starting at 10 percent of annual BLM production and ramping up thereafter – is workable. We believe that such an auction method harnesses free market forces to deliver a fair return to the US taxpayer, while not causing disruptions to the helium supply chain. Refiners currently have storage and delivery contracts with BLM that expire in 2015. It is these contracts, in turn, that have allowed us to enter into contracts with end users, the high tech manufacturers who are so reliant on helium to make their products and serve consumers. By phasing in the auction, we can continue to have dependable supplies of helium allowing us to offer long-term supply agreement so that these businesses can engage in essential planning and avoiding disruption in their operations.

Let me take a moment to describe the problem with the auction approach taken in the House bill. To our customers, helium is as essential to certain product lines as is electricity. Imagine if there was a semi-annual auction for electricity, and large manufacturers did not know, from one six month period to the next, if their particular power company “won” electricity or not. That is the consequence of the House's approach, except the essential input is not electricity but helium. Long-term planning will be impossible, and spot pricing will be the order of the day. This can hardly be deemed a positive outcome.

Helium customers would be faced with significant supply uncertainty and would not have the ability to plan as they do today. That is why the phased-in has such appeal.

For that reason, we will confess to concerns with even the Senate's auction in the out years, starting, say, when the auction will be 50 percent or higher. The good news is that new sources of helium appear quite likely to be coming on-stream by then, both in the US and around the world. If that were not the case, an auction of 50 percent or higher would raise questions about our ability to assure customers that they would know, with the certainty that they need, whether any helium refiner would have helium or not. We have the same misgivings as regards the federal users.

### **Assuring the greatest return for the taxpayer from sale of BLM helium**

Since this issue began receiving congressional attention last year, there has been a recurring theme: let's maximize the return to the US taxpayer. Refiners in general have no real stake in what price BLM establishes because our raw material costs are passed through to the market. Our main goal is assuring uninterrupted supply to our customers. But we should be clear about two facts. First, BLM could charge anything it wants for helium – today – under current law. There is no bar to BLM raising its pricing, and indeed, over the past three years, BLM has increased its prices by 30 percent, which we in turn had to pass on to our customers. Second, BLM could establish an auction under current law. There is no bar to that either. Should Congress be unable to reauthorize the helium statute, and should it be necessary to appropriate funds to keep the BLM helium program operating, BLM could raise its prices to whatever it wanted, and it could develop any lawful mechanism for selling the helium as well. Using the market survey that is included in S. 783, which BLM could do even without additional legislation, there is no reason that BLM could not be charging market price.

It appears that all this effort is going into a major revision of existing law because the National Academy of Sciences and Office of the Inspector General and Government Accounting Office all took a look at this issue and concluded that BLM wasn't getting a high enough price the helium it was selling. To repeat, BLM could charge anything it wanted to under existing law for its crude helium. But if the Committee is intent on directing BLM to do a better job of assessing what the "right" price should be, we think the direction to BLM to engage in a thorough confidential market survey, combined with at first a limited auction of the non-allocated amount of helium, will result in price discovery that will maximize the return to the taxpayer. This price – not the auction price, but a price that is arrived at through many factors including the auction price – would then be the price assigned to the allocated amount, that is, the amount not sold at auction.

### **Respecting existing contracts is critical**

Our contracts with BLM have been the bedrock of the ability to get helium to all of the customers – the large household name enterprises that justifiably want the BLM helium to remain accessible – who are intent, as we are, on getting legislation enacted in time. The provision in your bill that specifically respects existing contracts is important to keep the BLM system from being awash in litigation after enactment of new legislation. The *Winstar* case makes clear that Congress cannot pass legislation that necessitates a breach of contract without exposing the United States Government to liability for damages. Thankfully, your legislation does not appear do that.

### **Conditioning receipt of BLM helium on the requirement to "toll" for competitors is unnecessary**



A provision of the bill requires the refiners, as a condition to purchase non-auctioned crude helium, to make “excess refining capacity” available to those companies who succeed at auction that do not have refining capacity on the system “at commercially reasonable rates.” The Committee needs to understand that this provision is merely a statement of the current state of affairs and “Economics 101” in the helium business. If refiners do have excess capacity, they already do offer it to non-refiners at commercially reasonable rates. We refer to these as “tolling agreements”.

Our refineries receive helium not just from the BLM but from various other private companies who extract helium from natural gas in the panhandle region of the United States. We are contractually obligated to take the gas from these private sources. If there is a temporary slowdown in volume from the private sources, it may briefly appear that we have excess capacity, but we do not. The capacity that is contractually obligated to the private sources is NOT excess and cannot be used for other suppliers.

As the BLM helium supply declines, there will necessarily be refineries on the system that are not needed to be operational. We do not consider it appropriate for a statute to direct us to put into operation for the benefit of our competitors refining capacity that we have determined we do not need for ourselves.

If the Committee considers it essential to include a “tolling” provision in the legislation, we ask that “excess refining capacity” should only cover that capacity that is not “contractually obligated” and which is “operational.”

We believe that the most effective manner to incent refiners to provide tolling services is to prioritize delivery according to who wins it at auction. By prioritizing any helium purchased at auction, this assures the winner will have pipeline delivery priority and not impact any helium that a refiner may have access to, thus ensuring that there could be a competitive market for refiners to toll and ensure their plant is running at as high a capacity as possible.

We are in the business of selling helium, not of refining it for others who opted not to build their own refineries. If we truly have excess capacity, we put that capacity on the market. We recognize that the bill does not mandate tolling, yet it places a condition on our receipt of BLM helium that has the feel of interference in the free market, and puts us at the mercy of regulators or judges to determine the definition of a “commercially reasonable price” and whether capacity is truly “excess.” This does not seem to be an appropriate role for Congress. We doubt that any of our customers would like to have Congress direct them to make product for their competitors.

### **Important second tier issues the bill must address**

Unlike its House counterpart, your bill addresses issues that are important to the optimal functioning of the BLM system. For instance, it is essential to ensure that owners of previously purchased helium, currently sitting as inventory in the BLM reservoir, are able to withdraw their crude helium in order to service the market. The reason that helium is sitting in the reservoir, and is not being refined immediately after being purchased, is the limitation of the pipeline capacity. Your bill wisely recognizes that helium in inventory is necessary for the proper functioning of the system. This minimizes the risk that helium will be left stranded, or would have to be vented. The House bill, in contrast, would put hundreds of millions of dollars of purchased helium off limits for years, an obvious unconstitutional “taking,” and inconsistent with the smooth functioning of the overall system.

S. 783 provides for ongoing funding of operations and for the critical investments that will be necessary to support the BLM infrastructure – compression equipment, wells, and plant modifications, for instance. These improvements will be essential to ensure the maximum recovery of helium from the reservoir as it is depleted.

The “safety valve” is an important feature of S. 783, but in our view, it is important to give the Secretary full latitude to determine the amount to be auctioned. As the bill is currently written, the Secretary does not have the full discretion to manage auction amounts in a way that minimizes market disruption and increases returns to the U.S. taxpayer. This would require a small change in the bill so that the Secretary must meet the same standard, whether auction amounts are increased or decreased. We urge the Committee to give the Secretary full discretion to increase or decrease the amount to be auctioned, to minimize market disruption.

Finally, we are pleased that the bill addresses helium 3, an important strategic issue that needs and warrants attention from the federal government. There is currently an inter-agency task force, comprised of representatives from 14 separate agencies, looking at helium 3. The Department of Interior is not among those agencies. If the Secretary of Interior is to be given jurisdiction over helium 3 by virtue of the situation of BLM within the Department of the Interior, we recommend that the Secretary be directed to consult with the members of the task force before proceeding on this issue.

## **Conclusion**

The world helium markets are in a state of transition and uncertainty, and the world’s current largest supplier – the BLM reservoir – is in decline. Significant new sources are coming on line, but there have been repeated delays, and some of them are in politically unstable regions of the world. Shortages are creating tremendous volatility in the spot markets. This is not the type of environment in which to experiment with wholesale, untested changes in the world’s most stable source of supply – the BLM Reserve. This environment calls for level-headed reforms that are phased in incrementally. That is exactly the approach you have taken. Your bill would ensure that taxpayers get a fair market price for the government’s helium, while preserving much of the stability that has benefited consumers and high-tech manufacturers across the country.

Congress got it right when it established the federal helium reservoir and the surrounding infrastructure managed by BLM. The system has worked well for decades. Congress got it right yet again in the Helium Privatization Act of 1996, when it set in motion a process for selling off the helium previously captured in the federal reservoir. End users have had helium when they need it, and price and access have been stable. The public does not think much about helium – aside from party balloons and blimps – because the system has worked so well.

S. 783 is a good bill. Apart from the needlessly intrusive tolling provision, we are highly supportive of it, and we would expect that all stakeholders would share this view. Unlike its House counterpart, if S. 783 became law, it would allow helium to flow uninterrupted through the BLM system, there would be limited change in the supply of helium to end users, and BLM would have full authority – which we believe it has today - to charge full market rates for helium, thus assuring a healthy return to the US taxpayer.

The Senate’s approach to the helium issue, from the start, has been informed, measured, pragmatic, and workable. Since our business rests on implementation of a workable method for moving BLM’s

helium reserves to end users, we want to do everything we can to see that the Senate's approach is enacted. We have been gratified by the bipartisan, non-ideological support this Committee's leaders commanded for their helium bill last year, and we are pleased to see the same this year. Air Products appreciates the opportunity to testify again on this issue, and will do everything we can with our know-how to advise Congress along the way to an outcome that everyone can be proud of.

Mr. Chairman and Senator Murkowski, thank you for the pragmatic approach you have taken to this complicated issue. We stand ready to work with the Committee to assure that we avert the helium cliff and develop effective legislation that the President can sign into law.

Walter L. Nelson  
Director, Helium Sourcing & Supply Chain  
Air Products and Chemicals, Inc.  
7201 Hamilton Blvd.  
Allentown, PA 18195-1501  
Tel (610) 481-4911  
nelsonw2@airproducts.com

# The BLM Helium System

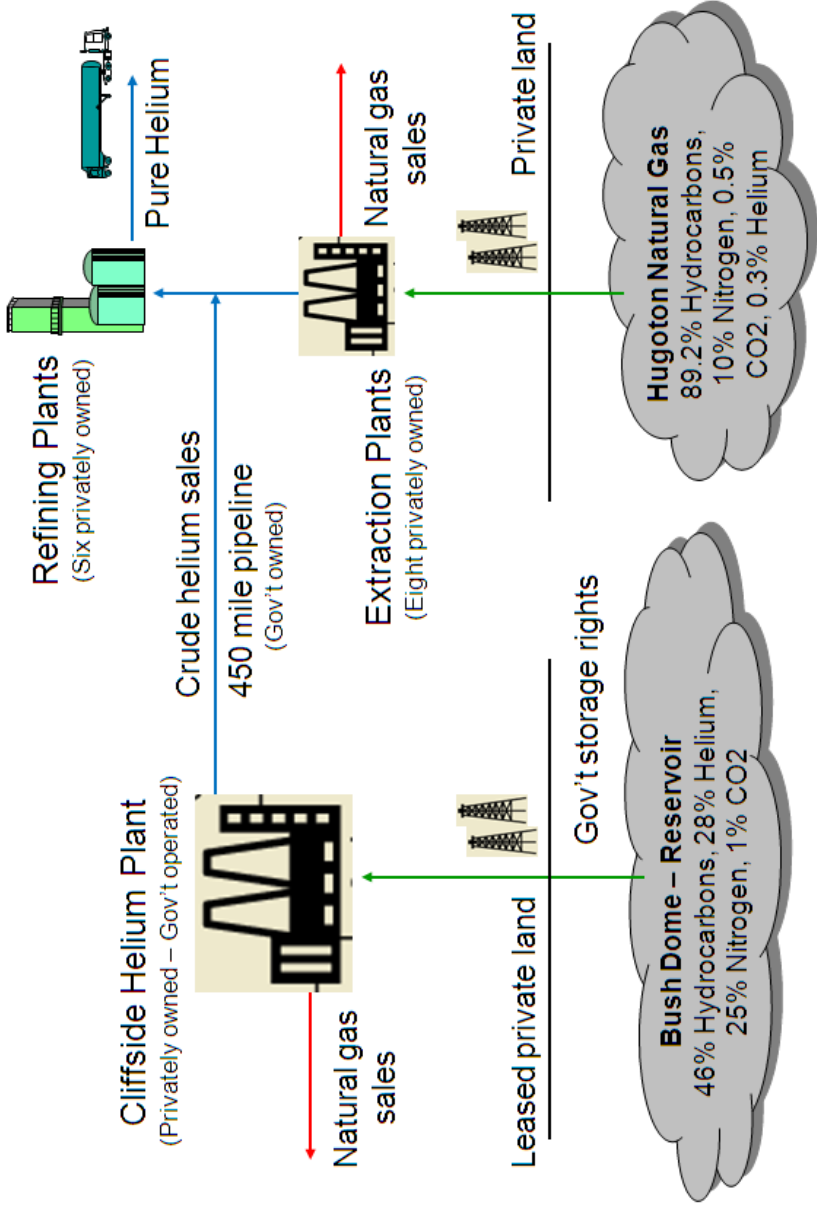

# Bush Dome Helium Production

